

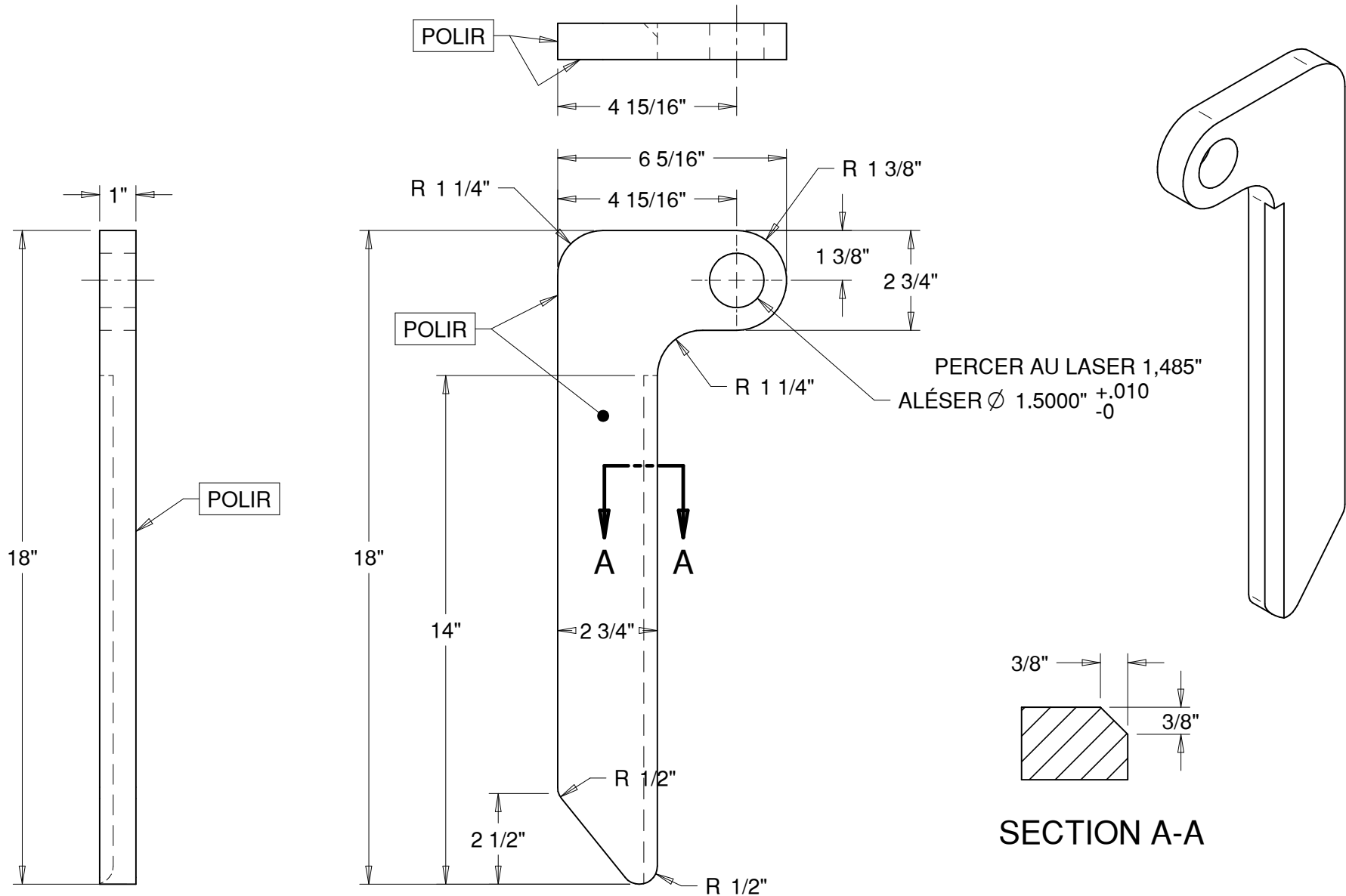

| No MAT / MAT No | MAT. | GRADE | TYPE | DIM. NOMINAL (PO) / NOMINAL DIM. (IN) | X DIM. | Y DIM. | POIDS / WEIGHT |
|-----------------|------|---------|------|---------------------------------------|------------|-----------|----------------|
| 700912 | ALU | 6061-T6 | PL | 1 | 18.0284 in | 6.3125 in | 5.218 lbm |



| GENERAL TOLERANCE | | REVISIONS | DATE | APPR. | DESS. / DRAFTSMAN | MODIFICATIONS | |
|--|-----------------|--|------------|---------|-------------------|---------------|----|
| IMP. FRACT. | IMP. DECIMAL | DESSINATEUR / DRAFTSMAN | DATE | SECTION | CONTRAT | DIM | PO |
| X = ± 1/16" | X. = ± 0.5 | danybrou | 2023-05-15 | . | | | |
| 1/X = ± 1/16" | X.X = ± 0.5 | NOM DU PRODUIT: | | | | | |
| 1/16 = ± 1/32" | X.XX = ± 0.05 | HOCKEY PORTE BATTANTE, TROTTOIR, BENNE COBRA DROITE +6" | | | | | |
| 1/32 = ± 1/64" | X.XXX = ± 0.005 | PRODUCT NAME: | | | | | |
| | | CURBSIDE, SWING DOOR HINGE, COBRA VERTICAL DOOR + 6" | | | | | |
| MM X. = ± 1 X.X = ± 0.5 ANGLE X° = ± 1° X.X° = ± 0.5° | |  ITEM PDM00005740-POLI / 01 | | | | | |